



MK4

Innovative
Solutions

 **FORTEC**

POST- TENSIONNING

Calle Can Nadal s/n Nave 1-A
08185 Lliça de Vall
Barcelona – Spain

+34 938 63 42 50
mk4@mekano4.com
www.mekano4.com

MK4

Innovative
Solutions

 **FORTEC**



01

MK4 System

Page 02 - Page 03

Introduction
Quality

02

The stressing tendon and its components

Page 04 - Page 15

Introduction
Strands
Ducts
Live End Anchorage TKA
Multiple Coupler TKB
Automatic Dead End anchorage TKP
Post-tensioning Slab System
Flat dead end anchorage MPC
Unbonded unitary anchorage MUNB 1/0.6"
Unitary Couplers
Tendon Properties

03

Stressing equipment

Page 16 - Page 18

Multi-Stressing Jacks
Mono-Stressing Jacks
Hydraulic Pumps
Blockout Dimensions and Requirements

04

Calculation notes

Page 19 - Page 28

Introduction

MeKano4 is specialised company that offers technical solutions for the construction of bridges and structures, by providing to the market a wide product and service range leading quality and services around the world.

Within our scope of activities, there is the design, supply and installation of stay cables, postensioning, bridge bearings and expansion joints for bridges, together with the supply of ground anchors and high tensile bars.

The MK4 postensioning system proposed, includes a gear range of anchorages, accessories and the necessary equipment to respond to the technical requirements for the construction of bridges and other structures.

The design and calculation of all the components were performed according to the new European code EAD 160004 - 00-0301 and EAD 160027 - 00-0301, which verification is an obligation in all post tensioning structures built in the European Union.

Our experience in many fields of post-tensioning applications and our team of engineers and technicians are the guarantee for our success and to face new challenges in the structural engineering field. As application, we are providing postensioning and cable stayed solutions for any structure as bridges, buildings, tanks of liquefied gas LNG, silos, covertures, communication towers, nuclear power stations, suspended structures, etc.

The services provided by Mekano4 include the following aspects:

- Technical assistance in all the phases of the project; from the design to the final execution.
- A large range of live end and dead end anchorages and couplers, being always ready for any development or change according to the specifics needs of the project.
- The designed system was successfully tested according to the new European standard EAD 160004 - 00-0301 and EAD 160027 - 00-0301 for postensioning systems.
- The possibility to use metallic and PE/PP ducts depending on the project specifications.
- Automatic and lightweight stressing equipment.
- Study of alternative design or construction method as an improvement for the optimum solution for every project.



MeKano4 has developed a complete Quality Assurance Programme conforming to ISO 9001:2000 and according to the requirements of the new European code EAD 160004 - 00-0301 and EAD 160027 - 00-0301 for Postensioning, including the design, production, supply and installation of all the required PT works, as anchorages, auxiliary equipment; pushing strands, stressing and injection.

By this way, this complete quality system covers all postensioning work performed by MeKano4.

MANAGEMENT SYSTEM CERTIFICATE

ISO 9001:2015

MeKano4 WORLD WIDE, S.L.
C/ Can Nadal Nave 1A-2, Pol. Ind. Can Nadal, 08185, Lliçà de Vall, Barcelona, Spain

conforme a la Norma del Sistema de Gestión de Calidad / has been found to conform to the Quality Management System standard: **ISO 9001:2015**

Este certificado es válido para el siguiente campo de aplicación:
 - DISEÑO E INSTALACIÓN DE SISTEMAS DE POSTERONADO Y SUS ANCLAJES ESPECIALES (TIRANTES DMK, PEXTERIOR Y EXTERNO).
 - DISEÑO, FABRICACIÓN Y SUMINISTRO DE SOPORTES ESTRUCTURALES DE TIPO ELIPSOIDAL, POT Y ESFERICO.
 - DISEÑO, FABRICACIÓN E INSTALACIÓN DE SOLUCIONES TECNOLÓGICAS DE ANCLAJE AL TENEDOR CON CORONES DE POSTERONADO.
 - DISEÑO E INSTALACIÓN DE JUNTAS DE EXPANSIÓN PARA PUENTES.

Este certificado es válido for the following scope:
 - DESIGN AND INSTALLATION OF POST-TENSIONING AND SPECIAL SOLUTIONS (DMK CABLE STAYS, EXTRADOSED AND EXTERNAL PT).
 - DESIGN, MANUFACTURING AND SUPPLY OF STRUCTURAL BEARINGS OF ELIPSOIDAL, POT AND SPHERICAL TYPE.
 - DESIGN, MANUFACTURING AND INSTALLATION OF TECHNICALLY ADVANCED GROUND ANCHORS WITH PT STRAINERS.
 - SUPPLY AND INSTALLATION OF BRIDGE EXPANSION JOINTS.

ENAC CERTIFICACION

Evaluación Técnica Europea **ETA 19/0065** de 14.06.2021

MeKano4 PT System TK, sistema de postesoado interior adherente desde 4 hasta 37 cordones

Organismo de Evaluación Técnica que emite la ETE: ITEC

Nombre comercial del producto de construcción: MeKano4 PT System TK, sistema de postesoado interior adherente desde 4 hasta 37 cordones

Área del producto a la que pertenece: 16 - Kits de postesoado.

Fabricante: MK4 World Wide, S.L. Pol. Ind. Can Nadal / C/ Can Nadal Nave 1A-2 (08185) Lliçà de Vall, Barcelona España

Planta de fabricación: MK4 World Wide, S.L. Pol. Ind. Can Nadal / C/ Can Nadal Nave 1A-2 (08185) Lliçà de Vall, Barcelona España

La presente Evaluación Técnica Europea contiene: 70 páginas incluyendo 28 anexos que forman parte integral de esta evaluación.

La presente Evaluación Técnica Europea emite de acuerdo con el Reglamento (UE) 305/2011, en base a: Documento de Evaluación Europea (EAD) 160004-00-0301. Kits de postesoado para el pretensado de estructuras. Edición setiembre 2016.

Esta versión substituye: ETA 19/0065, emitido el 07.06.2019

European Technical Assessment **ETA-12/0310** of 18.08.2017

MeKano4 PT System M, internal bonded post tensioning system with 4 to 37 strands

General part: Technical Assessment Body issuing the European Technical Assessment: Österreichisches Institut für Bautechnik (OIB)

Trade name of the construction product: MeKano4 PT System M, internal bonded post tensioning system with 4 to 37 strands

Product family to which the construction product belongs: Post tensioning kit for internal prestressing of structures with bonded strands

Manufacturer: MK4 World Wide, S.L. Pol. Ind. Can Nadal / C/ Can Nadal Nave 1A-2 (08185) Lliçà de Vall, Barcelona Spain

Manufacturing plant: MK4 Innovative Solutions, S.L.U. Pol. Ind. Can Nadal / C/ Can Nadal Nave 1A-2 (08185) Lliçà de Vall, Barcelona Spain

This European Technical Assessment contains: 74 pages including Annexes 1 to 70, which form an integral part of this assessment.

This European Technical Assessment is issued in accordance with Regulation (EU) No 305/2011, on the basis of: ETAG 013, Guidelines for European technical assessment for Post-Tensioning Kits for Prestressing of Structures, edition June 2002, used according to Article 6(3) of Regulation (EU) No 305/2011 as European Assessment Document.

This European Technical Assessment replaces: European technical approval ETA-12/0310 with validity from 29.08.2013 to 12.09.2017.

European Technical Assessment **ETA 22/0340** of 09.11.2022

MeKano4 WWWS PT System

General part: Technical Assessment Body issuing the ETA: ITEC

Trade name of the construction product: MeKano4 WWWS PT System

Product family to which the construction product belongs: 10 - Post tensioning kits.

Manufacturer: MK4 WORLD WIDE, S.L. Pol. Ind. Can Nadal / C/ Can Nadal Nave 1A-2 (08185) Lliçà de Vall, Barcelona Spain

Manufacturing plant(s): MK4 WORLD WIDE, S.L. Pol. Ind. Can Nadal / C/ Can Nadal Nave 1A-2 (08185) Lliçà de Vall, Barcelona Spain

This European Technical Assessment contains: 30 pages including 5 annexes which form an integral part of this assessment.

This European Technical Assessment is issued in accordance with Regulation (EU) 305/2011, on the basis of: European Assessment Document (EAD) 100004-00-0301. Post-tensioning kits for prestressing of structures. Edition September 2016.

European Technical Assessment **ETA 19/0064** of 14.06.2021

MeKano4 PT System E, external post tensioning system with 3 to 37 strands

General part: Technical Assessment Body issuing the ETA: ITEC

Trade name of the construction product: MeKano4 PT System E, external post tensioning system with 3 to 37 strands

Product family to which the construction product belongs: 10 - Post tensioning kits

Manufacturer: MK4 World Wide, S.L. Pol. Ind. Can Nadal / C/ Can Nadal Nave 1A-2 (08185) Lliçà de Vall, Barcelona Spain

Manufacturing plant(s): MK4 World Wide, S.L. Pol. Ind. Can Nadal / C/ Can Nadal Nave 1A-2 (08185) Lliçà de Vall, Barcelona Spain

This European Technical Assessment contains: 60 pages including 22 annexes which form an integral part of this assessment.

This European Technical Assessment is issued in accordance with Regulation (EU) 305/2011, on the basis of: European Assessment Document (EAD) 160004-00-0301. Post-tensioning kits for prestressing of structures. Edition September 2016.

This version replaces: ETA 19/0064, issued on 25.10.2019

CERTIFICATE OF CONSTANCY OF PERFORMANCE **1220-CPR-1348**

MeKano4 Post-Tensioning Slab System

Based on the market under the name of: MK4 WORLD WIDE SL

And produced in the manufactured plant: MK4 Innovative Solutions SLU

This certificate attests that all provisions concerning the assessment and verification of constancy of performance described in the: EAD 160004-00-0301, EAD 160027-00-0301.

under system 1+ for the performances set out in the ETA are applied and that the factory production control conducted by the manufacturer is assessed to ensure the constancy of performance of the construction product.

This certificate was first issued on 28.06.2013 and will remain valid as long as neither the ETA, the construction product, the ACP methods nor the manufacturing conditions in the plant are modified significantly, unless suspended or withdrawn by the ITEC.

FERRAN BERMEJO NUALART

CE

The stressing tendon



The tendon is the basic element of a post tensioning system. A tendon comprises one or more strands, constrained at both ends by a compact, efficient and easily installed anchorage and encapsulated throughout within a duct.

In the photograph a general scheme is shown of a tendon consisting of two part tendons joined by a coupler.

All tendons can either be pre-assembled and pulled into the duct or the strands pushed individually into the duct with the aid of a strand pusher, before or after concreting to suit the construction sequence. All tendons are stressed with the aid of hydraulic jacks.

Coupler

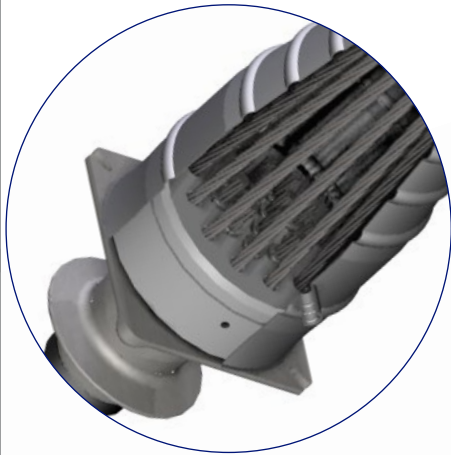

Live End



Dead End

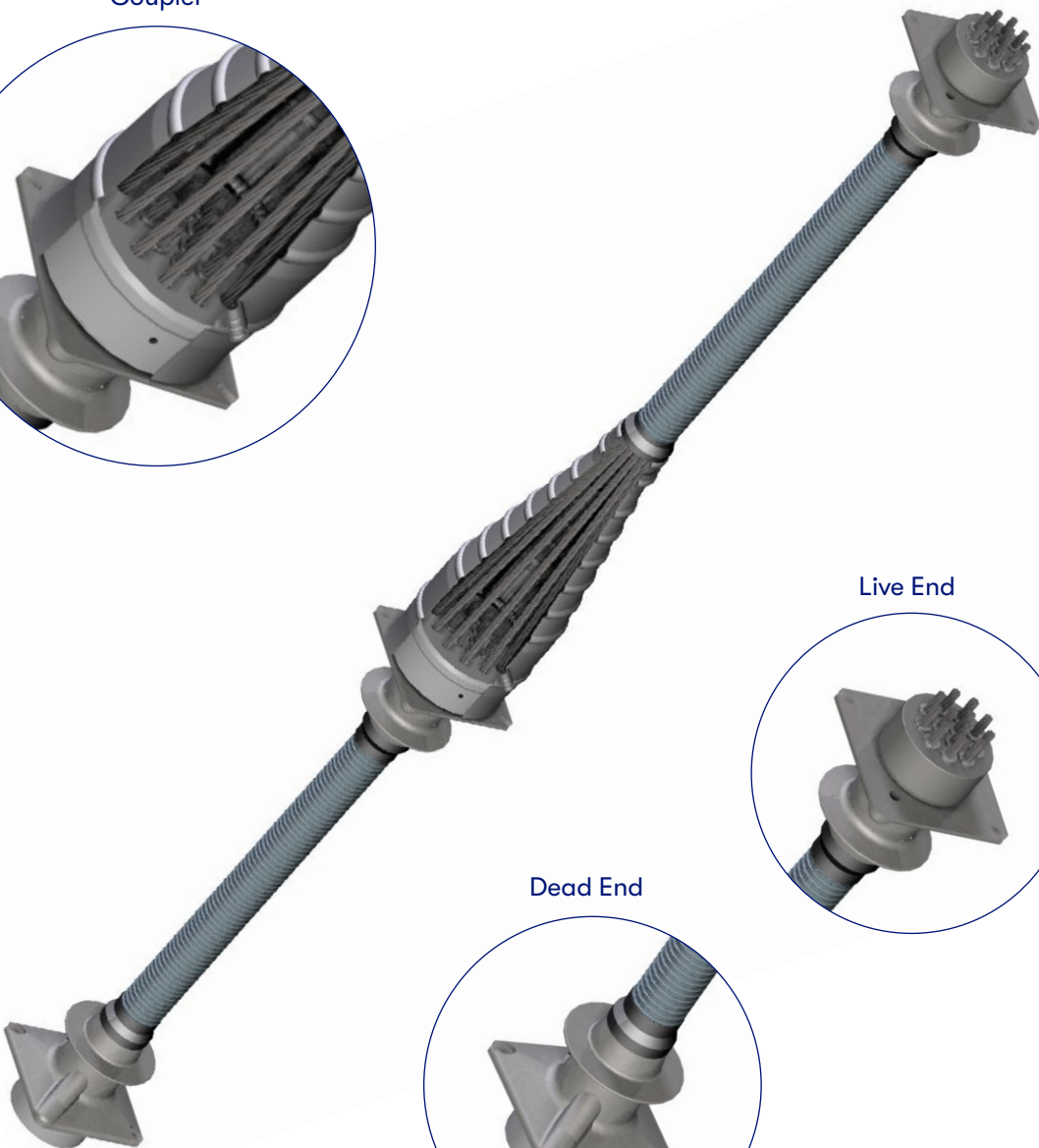
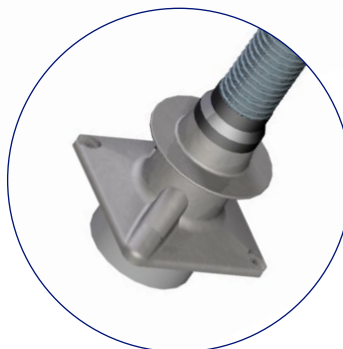

Strands

The strands used for post tensioning tendons are comprised of 7-wires low relaxation steel. The most common diameters are 0.6” (15.2/15.7 mm) and 0.5” (12.7/12.9 mm) corresponding to tensile strengths of 1770/1860 N/mm² and 1860 N/mm² respectively. The following table gives the main characteristics of each size of strand.



Strand type	Standard	Fpk	Nominal ø	Cross section	Weight	Min. breaking load f _{pk}	Relaxation 1000h at 70% of f _{pk}	Yield strength 0,1% strain
			mm	mm ²	g/m			
0,6” (15 mm)	EN 10138-3	1860 MPa	15,2	140	1.095	260	2,50%	224
	ASTM A416M-99	270 ksi	15,24	140	1.102	260,7	2,50%	234,6
	BS 5896:1980	1770 MPa	15,7	150	1.180	265	2,50%	225
	EN 10138-3	1860 MPa	16	150	1.170	279	2,50%	250
0,5” (13 mm)	ASTM A416M-99	270 ksi	12,7	98,71	775	183,7	2,50%	165,3
	BS 5896:1980	1860 MPa	12,9	100	785	186	2,50%	158
	EN 10138-3	1860 MPa	13	100	781	186	2,50%	160



Nominal ø	Standard	Initial post-tensioning force p ₀ (kn)		
		Eurocode 2 85% F _{p0,1} or 75% F _{pk}	EHE 08 75% F _{pk}	BS 5400-4 70% F _{pk}
mm				
15,2	EN 10138-3	190,4	195,0	182,0
15,24	ASTM A416M-99	195,5	195,5	182,5
15,7	BS 5896:1980	191,3	198,8	185,5
16	EN 10138-3	204,0	209,3	195,3
12,7	ASTM A416M-99	137,8	137,8	128,6
12,9	BS 5896:1980	134,3	139,5	130,2
13	EN 10138-3	136,0	139,5	130,2



Ducts

Post-tensioned tendons are encapsulated within the deck in a duct which is usually manufactured in corrugated steel (sometimes galvanised) with a wall thickness between 0.3 mm and 0.5 mm. In the table the sizes of the most frequently used ducts can be found.

The ducts are normally supplied in 4-6 m lengths and are coupled on site. Ducts are injected with cementitious grout, wax or other corrosion resistant compounds after stressing.

Strand	Tendon Type	Duct of Tendon	
		Inside ø mm	Outside ø mm
0,5" (13 mm)	4		
	7	51	56
	9	62	67
	12	72	77
	15		
	19	85	90
	22	90	95
	27	100	105
	31		
35	110	115	

Strand	Tendon Type	Duct of Tendon	
		Inside ø mm	Outside ø mm
0,6" (15 mm)	4		
	5	51	56
	7	62	67
	9	72	77
	12	85	90
	15	90	95
	19	100	105
	24	110	115
	27		
	31	120	125
	37	130	137
	43	140	147



HDPE and PP Ducts

For enhanced corrosion protection and fatigue resistance of the tendons, the use of corrugated high strength polyethylene (HDPE) and polypropylene (PP) products is highly recommended.

We can supply the following diameters: 59, 76, 100, 115, 130 mm. Please contact our technical department for further information.

MSA	PP Duct ø Int.
5	59
7	59
9	69
12	76
15	86
19	100
24	107
27	110
31	115
37	130
43	130

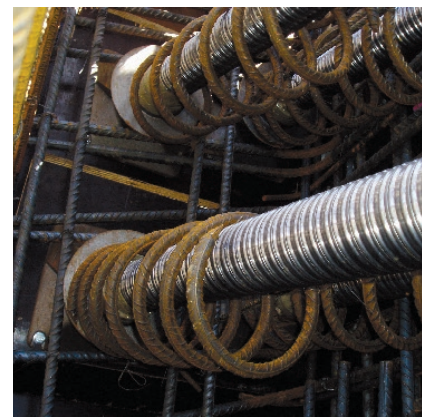

Live end anchorage TKA

The “Kompact” system is the outcome of more than 30 years of experience in the posttensioning industry. The upgrade in the quality and the strength of the concrete has brought to the market the “K” system as an answer to modern civil engineering requirements.

The main feature of the “Kompact” system is clearly the compactness. The compactness provides a reduction in the sizes of the webs, blisters and diaphragms of the decks. It reduces as well the rebar congestion achieving a transfer of the loads into the structure. This evolution looks to maximize the cost effectiveness of the posttensioning applications.

Like its brother “MSA” system, the “Kompact” systems has been designed and successfully tested to comply with the most demanding international standards such EAD 160004 - 00-0301 and EAD 160027 - 00-0301, FIB, PTI, BS, etc. The K system has a range available from 4 to 43 strands of 0,62” diameter.

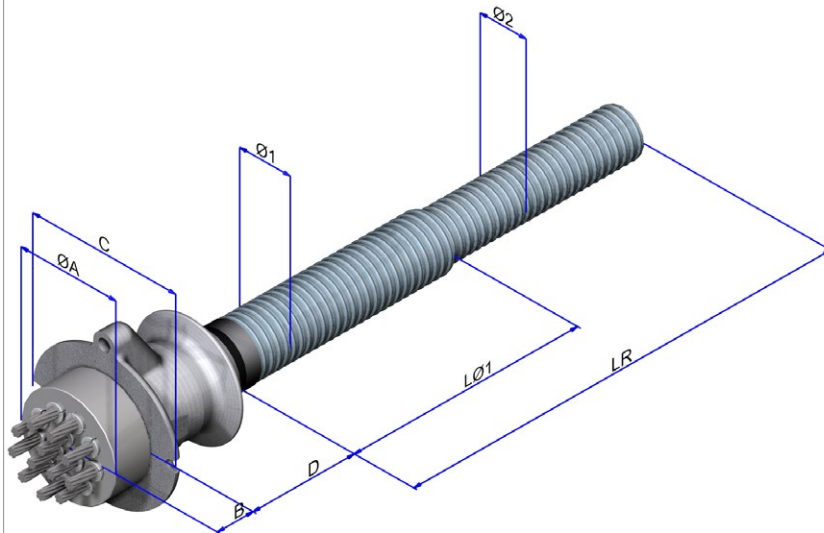

Strand Type	Tendon Type	Trumpet Type	ØA	B	C	D	LØ1	LR	Ø1	Ø2	Min. Curv. Radius
			mm	mm	mm	mm	mm	mm	mm	mm	mm
0,62” (15 mm)	4	TK5	110	50	160x150	130		600	103/108	48/53	2.700
	5	TK5	110	50	160x150	130		600	103/108	48/53	3.300
	7	TK7	130	60	180x160	140		600	103/108	57/62	3.900
	9	TK9	144	60	210x190	150		900	103/108	65/75	4.400
	12	TK12	165	72	240x220	170		900	103/108	75/80	5.100
	15	TK15	186	78	270x250	190		900	103/108	85/94	5.700
	19	TK19	200	94	300x270	220	250	1.200	140/147	95/104	6.400
	24	TK24	240	90	340x320	240		1.200	140/147	105/114	7.300
	27	TK31	252	105	360x340	275		1.500	140/147	115/124	7.500
	31	TK31	268	110	360x340	275		1.500	140/147	120/125	8.300
	37	TK37	296	120	410x380	300		1.500	140/147	130/137	9.100
43	TK43	330	140	460x430	340		1.500	150/157	140/147	9.800	

Multiple coupler TKB

The MKB coupler is a recent development in response to the need for a more compact system in connecting tendons in continuously stressed structures. With the same engineering philosophy of the MCB system, the continuity of the tendon is achieved by stressing the first stage as a normal live end and coupling the secondary tendon as an automatic dead end, with the lock spring and the wedge. The entire assembly is protected by a conical/cylindrical cover (trumpet) which has an inlet for the grouting operation.

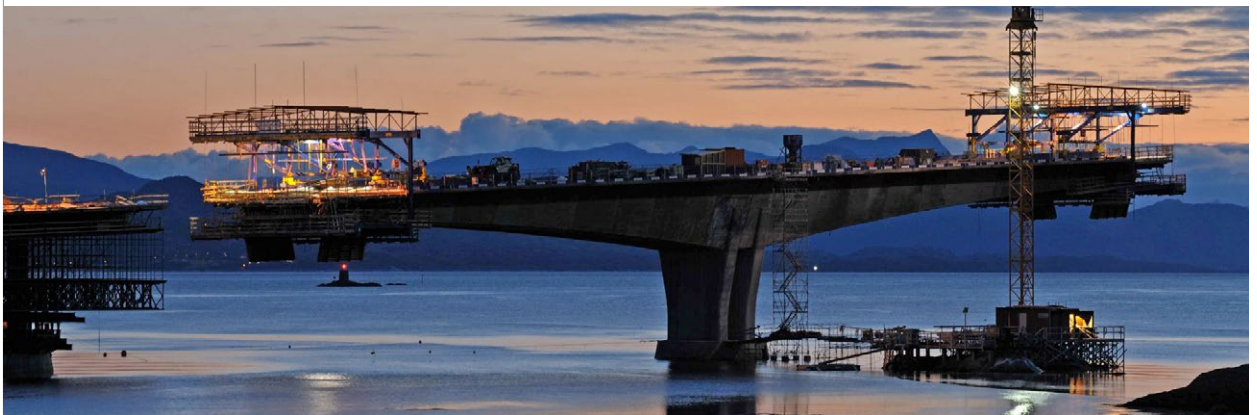
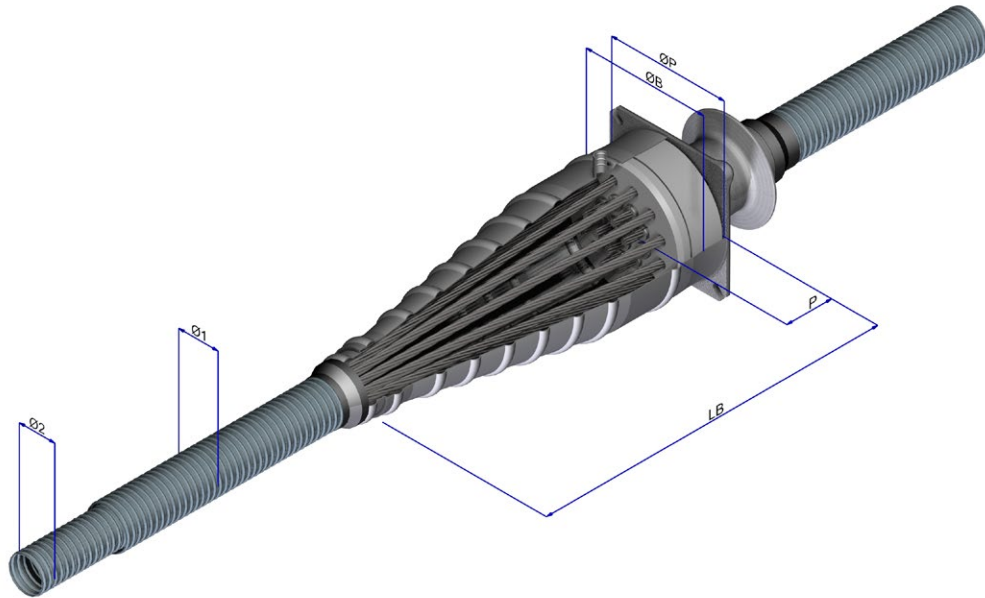

Strand Type	Tendon Type	Trumpet Type	ϕP	P	ϕB	LB	$\phi 1$	$\phi 2$	Min. Curv. Radius
			mm	mm	mm	mm	mm	mm	mm
0,62" (15 mm)	4	TK5	134	85	167	433	103/108	48/53	2.700
	5	TK5	150	85	167	433	103/108	48/53	3.300
	7	TK7	180	96	198	578	103/108	57/62	3.900
	9	TK9	200	95	218	636	103/108	65/75	4.400
	12	TK12	244	95	252	719	103/108	75/80	5.100
	15	TK15	265	100	287	723	103/108	85/94	5.700
	19	TK19	265	125	287	723	140/147	95/104	6.400
	24	TK24	315	120	335	1.015	140/147	105/114	7.300
	27	TK31	350	130	364	1.150	140/147	115/124	7.500
	31	TK31	350	130	364	1.162	140/147	120/125	8.300
	37	TK37	375	155	384	1.248	140/147	130/137	9.100
43	TK43	440	180	450	1.680	150/157	140/147	9.800	

Automatic dead end anchorage TKP

The MKA Automatic Dead End anchorage is a recent development in response to the need for a more compact system.

Its principal characteristic is the automatic retention of the strands by the anchor plate and its primary use is in situations where extrusion grips cannot be fitted satisfactorily due to space limitations.

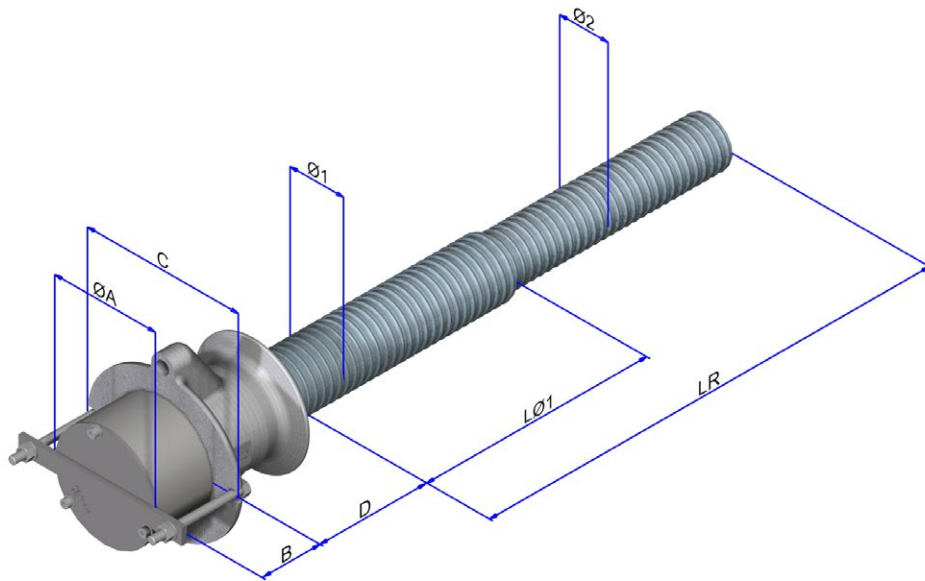

Strand Type	Tendon Type	Trumpet Type	ØA	B	C	D	LØ1	LR	Ø1	Ø2	Min. Curv. Radius
			mm	mm	mm	mm	mm	mm	mm	mm	mm
0,62" (15 mm)	4	TK5	110	88	160x150	130		600	103/108	48/53	2.700
	5	TK5	110	83	160x150	130		600	103/108	48/53	3.300
	7	TK7	129	99	180x160	140		600	103/108	57/62	3.900
	9	TK9	144	85	210x190	150		900	103/108	65/75	4.400
	12	TK12	170	90	240x220	170		900	103/108	75/80	5.100
	15	TK15	186	115	270x250	190		900	103/108	85/94	5.700
	19	TK19	200	127	300x270	220	250	1.200	140/147	95/104	6.400
	24	TK24	239	128	340x320	240		1.200	140/147	105/114	7.300
	27	TK31	252	143	360x340	275		1.500	140/147	115/124	7.500
	31	TK31	268	143	360x340	275		1.500	140/147	120/125	8.300
	37	TK37	296	161	410x380	300		1.500	140/147	130/137	9.100
43	TK43	330	177	460x430	340		1.500	150/157	140/147	9.800	

Post-tensioning Slab System

MK4 has developed an innovative Post-Tensioning anchorage, specifically for flat slabs. This new anchorage system is called Wedge Wedge System, its acronyms are WWS and it is patented.

Our range of sizes are for 2, 3 and 4 strands with 15,2/15,7 mm (0.6"/0.62") diameter and 3, 4, and 5 strands with 12,7/13 mm (0.5") diameter. The strands are tensioned and locked off individually using a mono-strand jack.

Strand Size	General Denomination					Dimension mm							
	Anchorage Type	Tendon Type	N° Strand	Casting Trumpet	Plastic Housing	Casting TrumpetP					lastic Housing		
						A	B	C	D	E	a	b	c
15,2 / 15,7 mm (0,6")	WWWS350	30.5"	3	T050	A050	170	95	49	142	82	72	150	65
	WWWS450	40.5"	4	T080	A080	220	105	56	197	99	103	200	82
	WWWS550	50.5"	5	T112	A112	260	110	57	227	110	135	250	94
12,7 / 12,9 mm (0,5")	WWWS262	20.6"	2	T050	A050	170	95	50	142	82	72	150	65
	WWWS362	30.6"	3	T080	A080	220	105	56	197	99	103	200	82
	WWWS462	40.6"	4	T112	A112	260	110	58	227	110	135	250	94

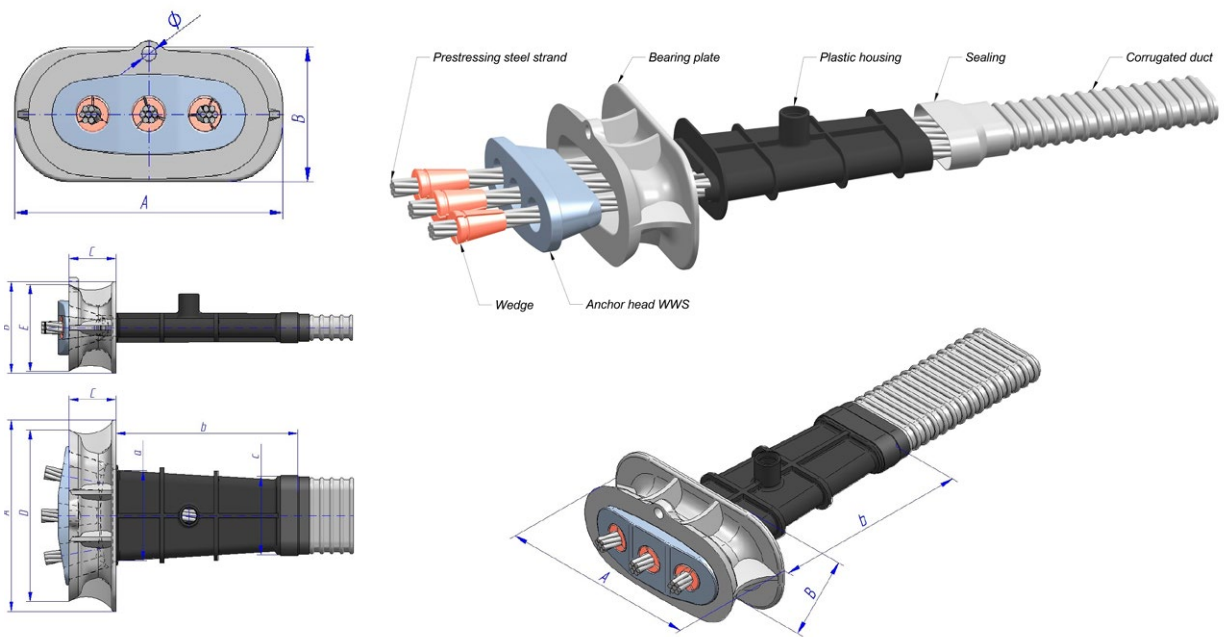

Flat Ducts

TYPE			
T050	21x45	19x43	22x38
T080	21x58	19x70	21x52
T112	21x70	19x70	21x72

Flat dead end anchorage MPC

For the dead end of the flat anchorages ML, we propose the anchorage type MPC, easy to execute and with high efficiency.

The anchorage lengths and the dimensions of the plate are indicated in the table. For more information contact with technical department.

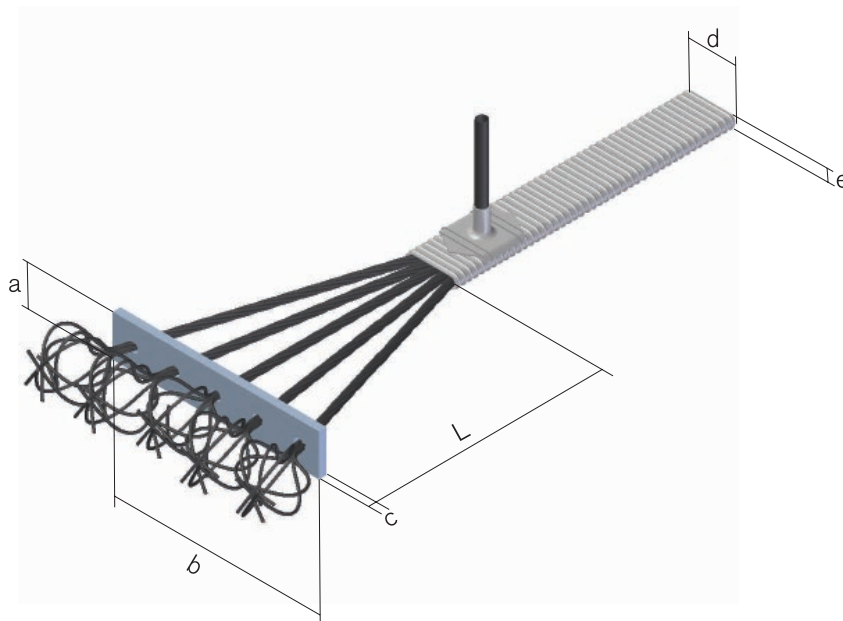

	a	b	c	d	e	L
4/0,5"	50	300	5	75	20	950
5/0,5"	50	375	5	75	20	950
4/0,6"	50	300	5	75	20	950
5/0,6"	50	375	5	95	20	950

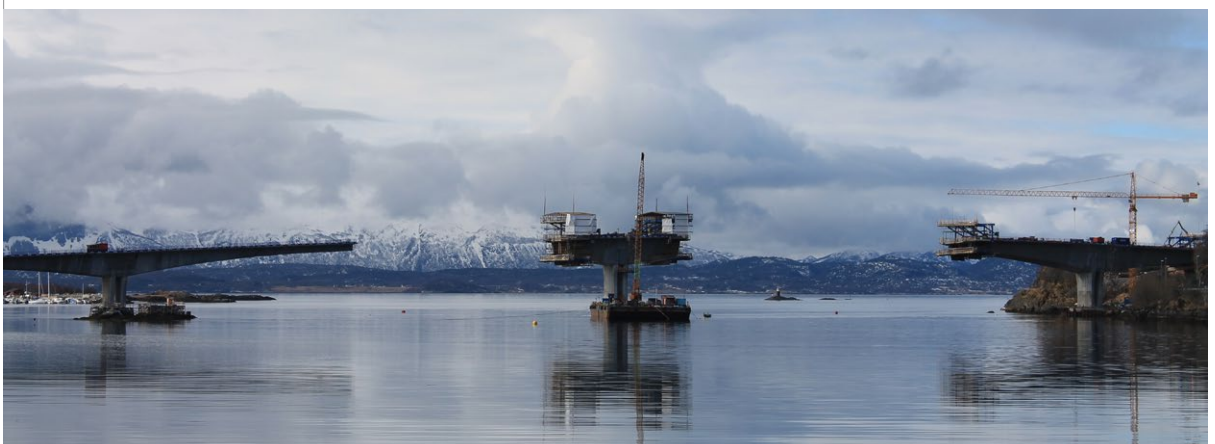

Unbonded unitary anchorage MUNB 1/0.6"

The MK4 unbonded mono-strand system uses 15 mm (0.6") diameter strand and a live end anchorage MUNB 1/0.6" which can also be used as a passive anchorage by incorporating a seal cap and a spring. The strands feature a factory applied corrosion protection system consisting of grease encasement in a polyethylene sheath.

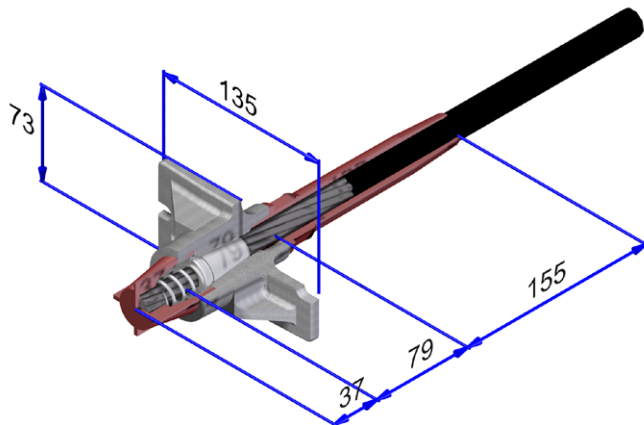

Bonded unitary anchorage MADH 1/0.6"

For every day more used bonded solution in building slab's, MK4 offers two possible options for the unitary anchorage: the Live End Anchorage MADH 0,6" and the Live End Global anchorage MAG 0,6". For both systems the inhibition of the corrosion is achieved by the injection of the grouting.

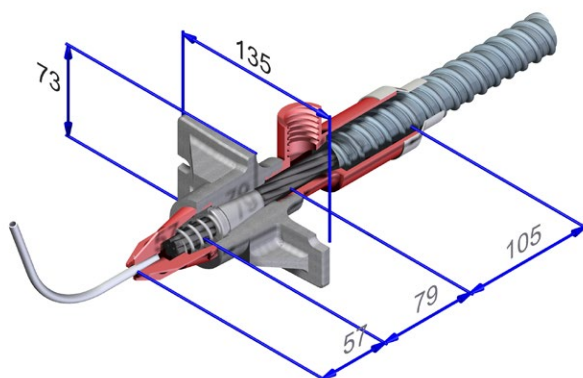

Unitary coupler MCU

The unitary coupler Type MCU is a single strand coupler –its main advantage being that it can be used in a limited work space.

It is an ideal system for bridge decks with limited thickness, where a multiple junction MCB might not fit into the allowable space.

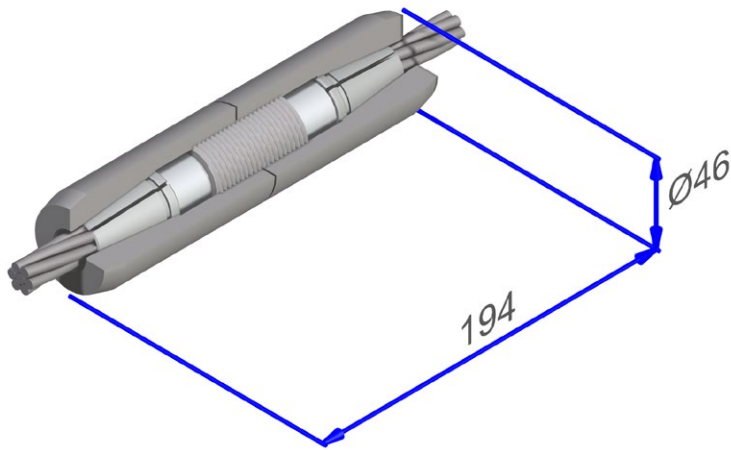

Tendon properties

STRAND 0,6"												
Tendon		Strand ø16 mm Y1860 S7 to EN 10138-3				Strand ø15,24 mm Grade 270 to ASTM A416M-99				Duct	Cement	Jack
Type	N° of Strands	Breaking Load F _{pk} (kN)	Tens. Force (1) P ₀ (kN)	Weight Kg/m	Section mm ²	Breaking Load F _{pk} (kN)	Tens. Force (2) P ₀ (kN)	Weight Kg/m	Section mm ²	Inside ø mm	Kg/ml	
1-0,6"	1	279	204	1,17	150	260,7	195,5	1,102	140	20	0,6	ARROW
4-0,6"	2	558	408	2,34	300	521	391	2,20	280	51	2,6	MS-1
	3	837	612	3,51	450	782	586	3,31	42			
5-0,6"	4	1.116	816	4,68	600	1.042	782	4,41	560	51	2,0	MS-2
	5	1.395	1.020	5,85	750	1.303	977	5,51	700			
7-0,6"	6	1.674	1.224	7,02	900	1.564	1.173	6,61	840	62	3,2	MS-2
	7	1.953	1.428	8,19	1.050	1.824	1.368	7,71	980			
9-0,6"	8	2.232	1.632	9,36	1.200	2.085	1.564	8,82	1.120	72	4,3	MS-3
	9	2.511	1.836	10,53	1.350	2.346	1.759	9,92	1.260			
12-0,6"	10	2.790	2.040	11,70	1.500	2.607	1.955	11,02	1.400	85	6,2	MS-3
	11	3.069	2.244	12,87	1.650	2.867	2.150	12,12	1.540			
	12	3.348	2.448	14,04	1.800	3.128	2.346	13,22	1.680			
15-0,6"	13	3.627	2.652	15,21	1.950	3.389	2.541	14,33	1.820	90	6,6	MS-4
	14	3.906	2.856	16,38	2.100	3.649	2.737	15,43	1.960			
	15	4.185	3.060	17,55	2.250	3.910	2.932	16,53	2.100			
19-0,6"	16	4.464	3.264	18,72	2.400	4.171	3.128	17,63	2.240	100	8,2	MS-4
	17	4.743	3.468	19,89	2.550	4.431	3.323	18,73	2.380			
	18	5.022	3.672	21,06	2.700	4.692	3.519	19,84	2.520			
	19	5.301	3.876	22,23	2.850	4.953	3.714	20,94	2.660			
24-0,6"	20	5.580	4.080	23,40	3.000	5.214	3.910	22,02	2.800	110	9,8	MS-6
	21	5.859	4.284	24,57	3.150	5.474	4.105	23,14	2.940			
	22	6.138	4.488	25,74	3.300	5.735	4.301	24,24	3.080			
	23	6.417	4.692	26,91	3.450	5.996	4.496	25,35	3.220			
	24	6.696	4.896	28,08	3.600	6.256	4.692	26,45	3.360			
27-0,6"	25	6.975	5.100	29,25	3.750	6.517	4.887	27,55	3.500	120	11,4	MS-7
	26	7.254	5.304	30,42	3.900	6.778	5.083	28,65	3.640			
	27	7.533	5.508	31,59	4.050	7.038	5.278	29,75	3.780			
31-0,6"	28	7.812	5.712	32,76	4.200	7.299	5.474	30,86	3.920	120	10,8	MS-7
	29	8.091	5.916	33,93	4.350	7.560	5.669	31,96	4.060			
	30	8.370	6.120	35,10	4.500	7.821	5.865	33,06	4.200			
	31	8.649	6.324	36,27	4.650	8.081	6.060	34,16	4.340			
37-0,6"	32	8.928	6.528	37,44	4.800	8.342	6.256	35,26	4.480	130	12,8	MS-8
	33	9.207	6.732	38,61	4.950	8.603	6.451	36,37	4.620			
	34	9.486	6.936	39,79	5.100	8.863	6.647	37,47	4.760			
	35	9.765	7.140	40,95	5.250	9.124	6.842	38,57	4.900			
	36	10.044	7.344	42,12	5.400	9.385	7.038	39,67	5.040			
	37	10.323	7.548	43,29	5.550	9.645	7.233	40,77	5.180			
43-0,6"	38	10.602	7.752	44,46	5.700	9.907	7.429	41,88	5.320	140	14,7	MS-14
	39	10.881	7.956	45,63	5.850	10.167	7.625	42,98	5.460			
	40	11.160	8.160	46,80	6.000	10.428	7.820	44,08	5.600			
	41	11.439	8.364	47,97	6.150	10.689	8.016	45,18	5.740			
	42	11.718	8.568	49,14	6.300	10.949	8.211	46,28	5.880			
	43	11.997	8.772	50,31	6.450	11.210	8.407	47,39	6.020			

(1) P₀ according Eurocode 2 [85% F_{p0,1} or 75% F_{pk}]

(2) P₀ according EHE 08 [75%F_{pk}]

Notes: For compact strands options please contact with our technical departament.

Tendon properties

STRAND 0,5"												
Tendon		Strand ø13 mm Y 1860 S7 to EN 10138-3				Strand ø12,7 mm Grade 270 to ASTM A416M-99				Duct	Cement	Jack
Type	N° of Strands	Breaking Load F _{pk} (kN)	Tens. Force (1) P ₀ (kN)	Weight Kg/m	Section mm ²	Breaking Load F _{pk} (kN)	Tens. Force (2) P ₀ (kN)	Weight Kg/m	Section mm ²	Inside ø mm	Kg/ml	
1-0,5"	1	186	136	0,78	100	183,7	137,8	0,775	99	20	0,6	ARROW
4-0,5"	2	372	272	1,56	200	367	275	1,55	197	51	2,7	MS-1
	3	558	408	2,34	300	551	416	2,33	296			
5-0,5"	4	744	544	3,12	400	734	551	3,10	394	51	2,4	MS-2
	5	930	680	3,91	500	918	689	3,88	493			
7-0,5"	6	1.116	818	4,69	600	1.102	826	4,65	592	51	2,2	MS-2
	7	1.302	952	5,47	700	1.285	964	5,43	690			
9-0,5"	8	1.488	1.088	6,25	800	1.469	1.102	6,20	789	62	3,3	MS-3
	9	1.674	1.224	7,03	900	1.653	1.240	6,98	888			
12-0,5"	10	1.860	1.360	7,81	1.000	1.837	1.378	7,75	987	72	4,5	MS-3
	11	2.046	1.496	8,59	1.100	2.020	1.515	8,53	1.087			
15-0,5"	12	2.232	1.632	9,37	1.200	2.204	1.653	9,30	1.184	72	4,4	MS-3
	13	2.418	1.768	10,15	1.300	2.388	1.791	10,08	1.283			
19-0,5"	14	2.604	1.904	10,93	1.400	2.571	1.929	10,85	1.381	72	3,9	MS-4
	15	2.790	2.040	11,72	1.500	2.755	2.067	11,63	1.480			
22-0,5"	16	2.976	2.176	12,50	1.600	2.939	2.204	12,40	1.579	85	6,0	MS-4
	17	3.162	2.312	13,28	1.700	3.122	2.342	13,18	1.678			
27-0,5"	18	3.348	2.448	14,06	1.800	3.306	2.480	13,95	1.776	85	5,8	MS-4
	19	3.534	2.584	14,84	1.900	3.490	2.618	14,73	1.875			
31-0,5"	20	3.720	2.720	15,62	2.000	3.674	2.756	15,50	1.974	90	6,4	MS-4
	21	3.906	2.856	16,40	2.100	3.857	2.896	16,28	2.072			
37-0,5"	22	4.092	2.992	17,18	2.200	4.041	3.031	17,05	2.171	90	6,1	MS-4
	23	4.278	3.128	17,96	2.300	4.225	3.169	17,83	2.270			
MS-6	24	4.464	3.264	18,74	2.400	4.408	3.307	18,60	2.369	100	8,1	MS-6
	25	4.650	3.400	19,53	2.500	4.592	3.445	19,38	2.467			
MS-6	26	4.836	3.536	20,31	2.600	4.776	3.582	20,15	2.566	100	8,0	MS-6
	27	5.022	3.672	21,09	2.700	4.959	3.720	20,93	2.665			
MS-6	28	5.208	3.808	21,87	2.800	5.143	3.858	21,70	2.763	110	9,8	MS-6
	29	5.394	3.944	22,65	2.900	5.327	3.996	22,48	2.862			
MS-6	30	5.580	4.080	23,43	3.000	5.511	4.134	23,25	2.961	110	9,7	MS-6
	31	5.766	4.216	24,21	3.100	5.694	4.271	24,03	3.060			
MS-6	32	5.952	4.352	24,99	3.200	5.878	4.409	24,80	3.158	110	9,2	MS-6
	33	6.138	4.488	25,77	3.300	6.062	4.547	25,58	3.257			
MS-6	34	6.324	4.624	26,55	3.400	6.245	4.685	26,35	3.356	110	9,1	MS-6
	35	6.510	4.760	27,34	3.500	6.429	4.823	27,13	3.454			
MS-6	36	6.696	4.896	28,08	3.600	6.613,2	4.960,8	27,90	3.564	110	8,8	MS-6
	37	6.882	5.032	28,86	3.700	6.796,9	5.098,6	28,68	3.663			

(1) Po according Eurocode 2 [85% Fp0,1 or 75% Fpk]

(2) Po according EHE 08 [75%Fpk]

Notes: For compact strands options please contact with our technical departament.

Multi-stressing jacks. MS series

The MK4 stressing jacks represent the fourth generation in multistressing equipment.

They incorporate innovative developments including compact design, high precision and ease of handling.

The MK4 stressing jacks are essentially centre hole rams of the double acting type with fixed cylinder and moving piston and are designed to work at a pressure of 700 bar.

The jacks internal unit can be rotated thereby facilitating easy alignment with the tendon.

The jacks can be operated in either the standard horizontal position or vertically and features an automatic hydraulic “lock off” device to positively seat the wedges and, thereby, minimise load losses at transfer.

All jacks are calibrated before delivery to site to establish individual force/pressure characteristics.



General Characteristics	ATB-1	ARROW-3	MS-1	MS-2	MS-3	MS-4	MS-6	MS-7	MS-8	MS-14
External Sleeve Diameter (mm)	170	135	317	352	484	559	652	703	754	890
Total Length of the jack (mm)	504	991	850	741	742	764	881	903	930	960
Maximum Length (mm)	610	1.196	1.150	960	952	966	1.136	1.156	1.185	1.160
Stressing Pressure Area (cm ²)	45,36	40.08	175,93	223,64	433,53	678,56	904,78	1.099,53	1.347,74	2.160,04
Stressing Stroke (mm)	105	205	300	219	210	202	255	253	255	200
Maximum Working Pressure (Bar)	637	605	580	690	700	700	660	600	660	700
Maximum Working Force (kN)	284	256	1.020	1.542	3.033	4.748	5.969	7.254	8.892	15.100
Total Weight (Kg)	18	35	155	275	385	565	820	900	1.010	2.350

MK4 monostressing jacks. arrow series

The Light Arrow Jack is primarily designed for the stressing of single strand active anchorages Type MUNB 1/0.6" and Flat Anchorages Type WW. This jack is lightweight, only 20 kgs (easily manhandable) and incorporates a power lock off to ensure that the wedges are correctly seated inside the barrel, thus preventing the release of the strand under force.



Hydraulic Pumps

A full range of hydraulic pump equipment and central console units trolley mounted is available.

In addition to the standard hydraulic pump BPE55 used with Arrow Jacks, MS1 and MS2, the new large capacity hydraulic pump BPT11 is available. This pump is intended to be used in tandem with the larger multi-strand jacks and is capable of operating the largest MK4 jack that is currently in production.



General Characteristics	
Oil Delivery	9,51/min
Maximum Oil Working Pressure	700 bar
Weight	500 Kg
Oil	ISO 46 or ISO 68 Hydraulic
Power	11kW 1.450 rpm
Cooling	Air Heat Interchanger
Electric Controls	24 V
Electric Supply	3 phase 380 V + neutral + ground (32 A - 50 Hz)
Dimensions (weight, width, length)	1.050 mm, 640 mm, 1.050 mm

Blockout dimensions and requirements

Attached table showing the block-out dimensions and over-length of strands with the space requirements for location of jacks.

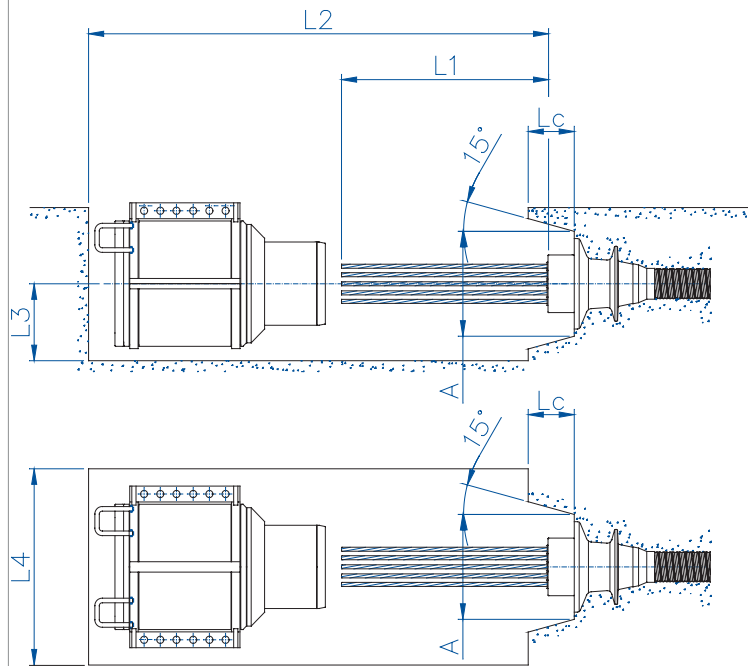

Strand	Tendon Type	L1	L2	L3	L4	A	LC
		mm	mm	mm	mm	mm	mm
0,6" (15 mm)	4	800	1.750	188	410	220	120
	5	800	1.650	200	450	220	120
	7	800	1.650	200	450	244	131
	9	850	1.700	240	580	270	130
	12	850	1.700	240	580	304	142
	15	900	1.750	280	660	332	148
	19	900	1.750	280	660	364	164
	24	1.000	2.000	380	760	406	165
	27	1.000	2.000	380	800	445	175
	31	1.000	2.000	380	800	445	185
0,5" (13 mm)	37	1.000	2.100	430	860	494	198
	43	950	2.060	430	1.000	510	210
	4	800	1.750	188	410	220	115
	5	800	1.750	188	410	220	115
	7	800	1.750	188	410	220	115
	9	800	1.650	200	450	244	120
	12	850	1.700	240	580	270	125
	15	850	1.700	240	580	304	130
	19	900	1.750	280	660	332	140
	22	900	1.750	280	660	364	145
27	1.000	2.000	380	760	445	155	
31	1.000	2.000	380	760	445	160	
35	1.000	2.000	380	760	445	165	

Note: Changes may be made to the information contained in this brochure at any time as new techniques and/or materials are developed.

MK4

Innovative
Solutions

CALCULATION NOTES

POST-TENSIONING

- 01 — **Introduction**
Page 02 - Page 03
- 02 — **Limitation of the prestressing force**
Page 02 - Page 03
- 03 — **Loss of prestress**
Page 02 - Page 03

 - A. Instantaneous losses**
 - a) Friction losses in the duct
 - b) Loss of prestress at transfer
 - c) Loss of prestress due to elastic deformation of concrete
 - B. Long term losses**
- 04 — **Tendon Elongation**
Page 02 - Page 03
- 05 — **Anchor Block**
Page 02 - Page 03

 - A. Bearing stresses**
 - B. Bursting tensile forces**

Introduction

For the design and application of post-tensioned tendons, consideration should be given to factors such as the following:

- I • Limitation of the prestressing force
- II • Loss of prestress
- III • Tendon elongation
- IV • Anchor block

The calculation methods that follow meet the requirements of the European Standard, EUROCODE 2 “Project of concrete structures” and the “Post-tensioning Manual” of the PTI (Post-tensioning Institute).

If these notes are used in countries where other standards are applicable a check should be made to ensure that calculations comply with local requirements.

Some paragraphs introduce notes referring to other standards, in this case the name of the standard is indicated.

Limitation of the prestressing force

Maximum initial prestress

Immediately after anchoring, the force in the post-tensioned tendon should not exceed the following values:

- EUROCODE 2 The minimum of the following values:
75% of the characteristic strength of the tendon
85% Yield strength (0,1% proof load)
- BS 5400-4 70% of the characteristic strength of the tendon

Jacking force

The Jacking force may be increased during stressing over the value of the maximum initial prestress up to the following limits:

- EUROCODE 2 The minimum of the following values:
80% of the characteristic strength of the tendon
90% Yield strength (0,1% proof load)
- BS 5400-4 80% of the characteristic strength of the tendon

These jacking force maximum values can only be applied temporarily to the tendon. Force in the tendon shall not exceed maximum initial prestress after transfer from the jack to the anchorage.

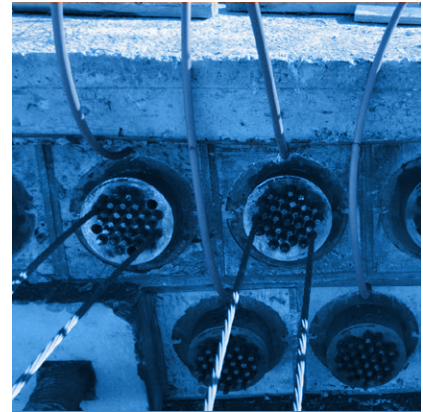

II. Loss of Prestress

The initial post-tensioning force applied to the live anchorage (P_0) is transmitted along the tendon, but decreases as a consequence of instantaneous and long term losses. The effective post-tensioning force (P_x) at each tendon point can be deduced as follows:

$$P_x = P_0 - \Delta P_i - \Delta P_{dif}$$

Where:

P_x = post-tensioning force at a point located at x meters from the anchorage.

P_0 = stressing force or initial post-tensioning force at anchorage (x=0).

ΔP_i = instantaneous post-tensioning losses.

ΔP_{dif} = long term post-tensioning losses.

In order to define with accuracy the value of P_0 , calibration curves for the equipment (jacks and manometers) shall be provided.

For the instantaneous losses the following parameters have to be considered:

- a) Friction of the duct with the tendon.
- b) Draw in of the anchorage wedges.
- c) Elastic deformation of the concrete.

For long term losses the following need to be considered:

- d) Shrinkage of the concrete.
- e) Creep of the concrete.
- f) Relaxation of the steel.

A. Instantaneous Losses

a) Friction Losses in the Duct

The losses due to friction are calculated in accordance with Coulomb formulae.

$$\Delta P_i = P_0 \left(1 - e^{-(\mu\alpha + kx)} \right)$$

Where:

μ = coefficient of angular friction (in rad^{-1}).

α = accumulated angular deviation between points 0 and x (radians).

k = wobble coefficient per unit length of tendon (in m^{-1}).

The friction coefficient depends on various factors such as the condition of the duct inner surface, the condition of the strand external surface and the tendon layout.

When $\mu\alpha + kx \leq 0,3$ the following approximate linear equation is used:

$$\Delta P_i = P_0 (\mu\alpha + kx)$$

Friction coefficient		μ (rad-1)	k (10-3 m-1)
Non lubricated tendons	Range calculation value	0,18-0,26 0,22	0,0006-0,0033 0,0025
Lubricated tendons	Range calculation value	0,05-0,15 0,0035	0,0016-0,005 0,0035
Unbonded tendons	Range calculation value	0,06	0,0005

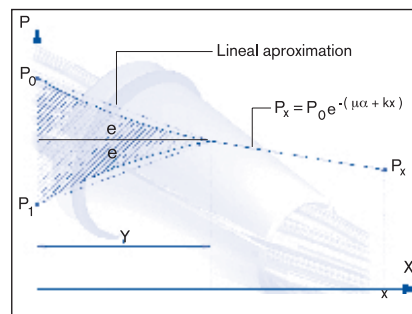
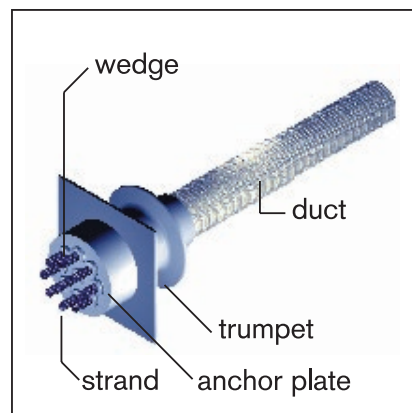
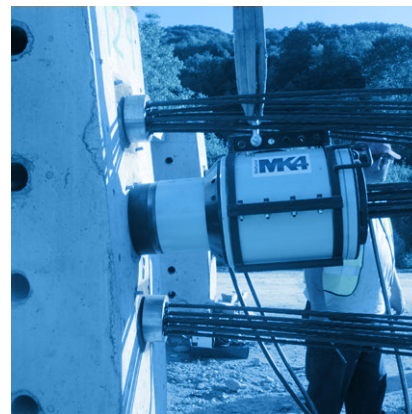

Figure 1

b) Loss of Prestress at Transfer

A loss of prestress occurs when the load is transferred from the stressing jack to the anchorage of the tendon. This loss of prestress during transfer is the result of a shortening of the tendon at transfer due to the draw in of the anchorage wedges, slippage of strand relative to the wedges and the adjustment of the anchorage plate on the trumpet.

After stressing, the wedges are then firmly pushed into its anchorage by the application of a hydraulic wedge seating feature. The jack is then retracted thus transmitting the force of the tendon to the anchorage plate.

As a result of this procedure the wedge still penetrates into the anchorage for several millimetres, until equilibrium of the tension and deformation is achieved. Slippage of the strand and adjustment of anchorage plate are almost negligible. The culmination of all these factors, results in a shortening of the tendon and therefore in a loss of prestressing force, and is referred to as “Draw in of the wedge” amounting between 4 to 6 mm for the MeKano4 prestressing system.

Due to friction losses the loss of prestressing due to draw in of the wedges affects only a certain length of the tendon from a maximum loss at the stressing anchorage till a nil loss at a length “ l_a ” from the anchorage.

In the case of short tendons, special attention should be given to the effect of the losses due to the draw in of the wedges, since tension losses due to the same tendon shortening are far higher in this case.

$$l_a = \frac{\alpha E_p A_p}{P_o (\mu \alpha + k l_a)}$$

l_a is calculated in an iterative process.

Where:

l_a = Length affected by the draw in of the wedge (m).

α = Draw in of the wedge (4-6 mm) (m).

E_p = Modulus of Elasticity of the prestressing steel (kN/mm²).

A_p = Area of prestressing tendons (mm²).

Losses due to draw in of the wedge (P_2) are calculated as follows:

$$\Delta P_2 = 2P_o \left(1 - e^{-(\mu \alpha + k l_a)} \right)$$

c) Loss of Prestress due to Elastic Deformation of Concrete

During the stressing process of the tendons, concrete suffers an immediate elastic shortening due to the compression force that is being introduced. If all tendons of the concrete section are not stressed simultaneously, there is a progressive loss of prestress due to the shortening of the tendons produced by the deformation of the concrete. Assuming that all tendons experience a uniform shortening and are stressed one after the other in a unique operation, losses can be calculated with the following expression:

$$\Delta P_3 = \frac{n-1}{2n} \frac{E_p}{E_{cj}} A_p \sigma_{cp}$$



Where:

σ_{cp} : Concrete compressive stress at the level of the c.o.g. of the tendons due to the post-tensioning force and actuating forces at the stressing moment.

$$\sigma_{cp} = \frac{P_0 - \Delta P_1 - \Delta P_2}{A_c} + \frac{(P_0 - \Delta P_1 - \Delta P_2) e^2 - M_{cp} \cdot e}{I_c}$$

E_{cj} : Modulus of elasticity of the concrete at j days.

e: Eccentricity of the tendon with reference to centre of gravity of the concrete section.

I_c : Second moment of area of the concrete section.

M_{cp} : Maximum moment in the concrete section.

A_c : Area of the concrete section.

n: Number of stressed tendons in the concrete section.

j: Age at application of prestressing force.

B. Long Term Losses

These prestress losses occur as a result of concrete creep and shrinkage as well as strand steel relaxation.

Long term losses are calculated using the following formula:

$$\Delta P_{diff} = \frac{n\varphi(t, t_0)\sigma_{cp} + E_p \varepsilon_{cs}(t, t_0) + 0.80 \Delta\sigma_{pr}}{1 + n \frac{A_p}{A_c} \left(1 + \frac{A_c y_p^2}{I_c}\right) (1 + x\varphi(t, t_0))} A_p$$

Where:

n: Ratio between modulus of elasticity of the prestressing steel and the modulus of elasticity of the concrete: E_p/E_c

$\varphi(t, t_0)$: Creep coefficient at the time of tensioning the tendons.

σ_{cp} : Concrete compressive stress at the level of the c.o.g. of the tendons due to the post tensioning force, dead load and superimposed dead load.

ε_{cs} : Strain due shrinkage of the concrete.

Assumed as approximate value: $\varepsilon_{cs} = 0.4$ mm/m at time infinite.

σ_{pr} : Stress due to the steel relaxation:

$$\Delta\sigma_{pr} = \rho_f \frac{P_0 - \Delta P_1 - \Delta P_2 - \Delta P_3}{A_p}$$

ρ_f : Relaxation value of prestressing steel at time infinite.

Assumed as approximate values: $\rho_f = 0,029$ at 60% of GUTS

$\rho_f = 0,058$ at 70% of GUTS

(GUTS – guaranteed ultimate tensile strength of prestressing steel)

$y_p = e$: Distance between the centre of gravity of the concrete section and centre of gravity of the prestressing tendons.

x = 0,8: coefficient of concrete age.

M_{cp} : Moment due to dead load and superimposed dead load in the concrete section.

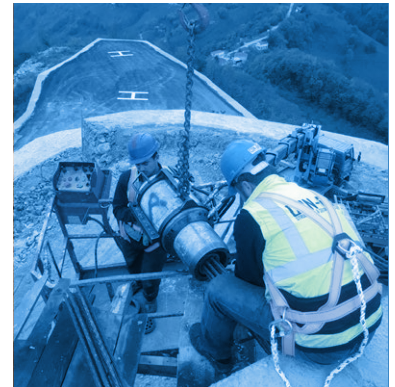

III. Tendon elongation

Stressing operation of tendons is carried out in a controlled process where elongation and gauge pressures are measured at all steps.

The final elongation of a tendon, obtained by in situ calculation, is compared to the theoretical elongation value in order to check if the result is acceptable.

The elongation of a post-tensioned tendon is assumed to be linear and is calculated with the use of the Hooke's Law.

$$\Delta l = \epsilon \cdot l = \frac{\sigma_s l}{E_p}$$

Where:

Δl : Tendon elongation.

l : Length of the tendon.

$\epsilon \cdot l$: Tendon strain per unit of length.

σ_s : Prestressing steel tensile stress ($\sigma_s = P/A_p$).

Due to the post tensioning losses, the elongation is given as a function of the force exerted on every section of the tendon.

$$\Delta l = \int_0^l \frac{\sigma_s}{E_p} dx$$

The elongation is proportional to the area under the curve of the post-tensioning force applied on the tendon (refer to figure 2).

$$\Delta l = \frac{l}{A_p E_p} \int_0^l P_x dx$$

Where:

l : Length of the tendon.

P_x : Prestressing force at section "x" (Jacking force minus friction losses).

If the tendon has two live end anchors, it can be post-tensioned from both ends and thus the elongation of the tendon is now proportional to the area under the graph of both post tensioning forces applied at both ends of the tendon, i.e. proportional to area A1+A2 (refer to figure 3).

IV. Anchor block

The anchor block is defined as the highly stressed zone of concrete around the two end points of a post tensioned tendon. It extends from the tendon anchorage to that section of the concrete at which linear distribution of stress is assumed to occur over the whole cross section.

For the design of the anchor blocks it is convenient to consider and check two different kind of stresses and forces that are produced around the prestressing anchorage:

- a) bearing stresses.
- b) bursting tensile forces.

Checking the bearing stresses will help to determine if the type of anchorage that has been chosen is valid and if the concrete compressive stress is acceptable.

Checking the bursting tensile forces will be necessary to evaluate the required anchorage bursting reinforcement.

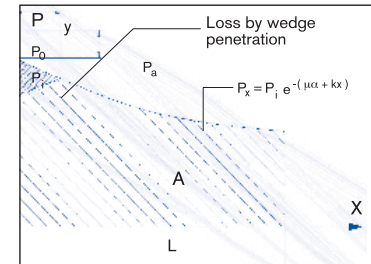

Figure 2

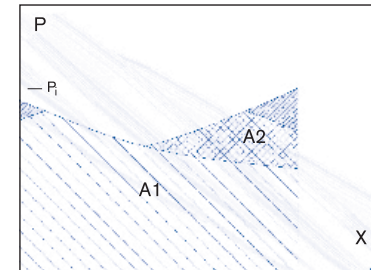
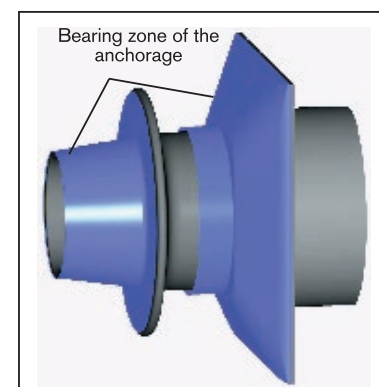

Figure 3



A. Bearing Stresses

The force that is transmitted through the bearing zone of the anchorage to the end block produces a high concrete compressive strength that can be evaluated as follows:

$$\sigma_c = \frac{P}{A_b}$$

Where:

P: Force applied on the anchorage.

A_b: Bearing area of the anchorage.

The bearing area for the different trumpets of the MK4 system anchors is as listed in the following table.

The compression tension in the bearing zone of the anchorage should be checked at two different stages:

- At transfer load (Jacking force)

$$\sigma_{co} = \frac{P_o}{A_b}$$

P_o: Maximum Jacking force applied to the anchorage at stressing.

A_b: Bearing area of the anchorage.

σ_{co}: Concrete compressive stress at transfer load.

σ_{co} should not exceed the lowest of the following two values of c_{po} (permissible

compressive concrete stress at transfer load).

$$\sigma_{co} \leq \sigma_{cov} = 0.8f_{ci} \sqrt{\left(\frac{A'_b}{A_b} - 0.2\right)}$$

$$\sigma_{co} \leq \sigma_{cov} = 1.25f_{ci}$$

Where:

f_{ci}: Concrete compressive strength at the time of stressing.

A'_b: Area of the anchor block - Maximum area of concrete concentric with the anchorage and limited by the concrete borders of the section or another anchor block.

- At service load

$$\sigma_{cs} = \frac{P_s}{A_b}$$

σ_{cs}: Concrete compressive stress at service load.

P_s: Prestressing force of the post-tensioned tendon at service.

Service load can be calculated deducting all type of prestress losses from the initial force at the anchorage zone.

Assumed Service load: 80% of the jacking force.

σ_{cs} should not exceed the lowest of the two following values of σ_{cps} (permissible compressive concrete stress at transfer load).

$$\sigma_{cs} \leq \sigma_{cps} = 0.6f_c \sqrt{\left(\frac{A'_b}{A_b}\right)}$$

$$\sigma_{cs} \leq \sigma_{cps} = 1.25f_c$$

Where:

f_c: Characteristic concrete compressive strength.

Anchorage Type		Anchorage Bearing Area
0,6" (15 mm)	0,5" (13 mm)	cm ²
	4/0,5"	328
	5/0,5"	328
4/0,6"		328
	7/0,5"	328
5/0,6"		328
	9/0,5"	454
7/0,6"		454
	12/0,5"	582
9/0,6"		582
	15/0,5"	778
12/0,6"		778
	19/0,5"	981
	22/0,5"	1.218
15/0,6"		981
	27/0,5"	1.561
19/0,6"		1.218
	31/0,5"	1.561
	35/0,5"	1.561
24/0,6"		1.561
27/0,6"		2.050
31/0,6"		2.050
37/0,6"		2.487
43/0,6"		2.822



B. Bursting Tensile Forces

In the anchor block some severe transversal tensile forces appear that should be absorbed by steel reinforcement. These bursting tensile forces are produced from the curvature of the force line and are originated at the bearing zone of the anchorage where the force lines divert until they reach a uniform distribution.

Figure 6 shows the distribution of stresses due to the bursting tensile force, perpendicular to the centre line of the tendon.

To determine the value of the bursting tensile forces the following formula can be used.

$$f_s A_s = Z = 0.25 P_o \left(1 - \frac{\Omega a_i}{d}\right)$$

Where:

Z: Total bursting tensile force.

f_s : Design strength for the bursting reinforcement.

Assumed design strength:

400 N/mm²* (for 500 N/mm² Yield load Steel).

A_s : Area of steel required for the bursting reinforcement.

P_o : Maximum jacking force at stressing.

Ω : Shape factor.

Assumed shape factors:

$\Omega=1$ for anchors with a unique bearing plate without ribs.

$\Omega=0,93$ for MeKano4 anchors with ribs.

*Note: Besides limiting the design strength for the bursting reinforcement to a maximum of 80% of the yield load, it is also convenient to limit the stress to a value corresponding to a steel strain of 0.002. This last limit has to be reduced to a steel strain of 0.001 on areas where the concrete cover is less than 50 mm.

Anchorage bursting reinforcement for the MK4-MS anchors is listed in the following table. To prepare the table following assumptions have been made:

Prestressing force = 85% of the characteristic strength of the tendon.

Ratio between anchorage upper plate side and anchor block side (a_1/d) = 0.5.

Concrete compressive strength: 28 N/mm² (Cylindrical test sample)

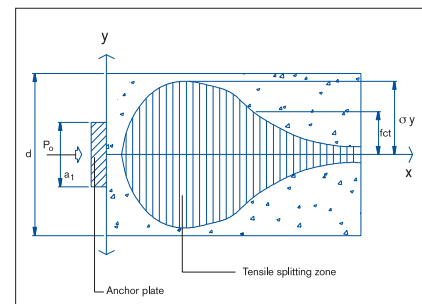
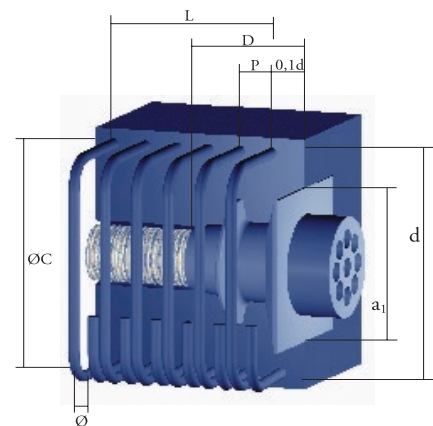
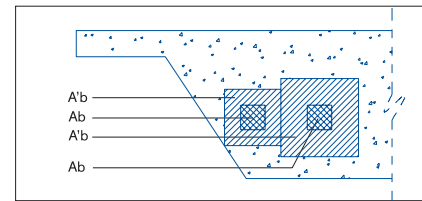

Figure 6



CALCULATION NOTES

Anchorages		Trumpet	α_1	D	L	P	ϕ_C	cir.	ϕ
15 mm	13 mm		mm	mm	mm	mm	mm	units	mm
	4/0,5"	T-4	170	155	240	80	210	4	10
	5/0,5"	T-4	170	155	240	80	210	4	10
4/0,6"		T-4	170	155	240	80	210	4	12
	7/0,5"	T-4	170	155	240	80	210	4	12
5/0,6"		T-4	170	155	240	60	210	5	12
	9/0,5"	T-5	194	150	285	95	260	4	14
7/0,6"		T-5	194	150	280	70	260	5	14
9/0,6"		T-6	220	175	320	80	310	5	14
	12/0,5"	T-6	220	175	325	65	310	6	14
	15/0,5"	T-7	254	200	360	90	350	5	16
	12/0,6"	T-7	254	200	375	75	350	6	16
	19/0,5"	T-8	282	235	400	80	400	6	16
	22/0,5"	T-19	314	230	440	110	440	5	20
15/0,6"		T-8	282	235	420	60	400	8	16
	27/0,5"	TR-24	356	520	510	170	500	4	25
19/0,6"		T-19	314	230	450	90	440	6	20
	31/0,5"	TR-24	356	520	510	170	500	4	25
	35/0,5"	TR-24	356	520	500	125	500	5	25
24/0,6"		TR-24	356	520	500	125	500	5	25
27/0,6"		TR-31	395	570	575	115	560	6	25
31/0,6"		TR-31	395	570	570	95	560	7	25
37/0,6"		TR-37	444	670	630	90	620	8	25
43/0,6"		TR-43	490	1.100	720	80	680	10	25

Note: $\alpha_1/d=0,5$ Concrete compressive strength=28 N/mm²

If the value of α_1/d is not equal to 0.5 and the concrete compressive strength is different to 28 N/mm², the bursting reinforcement listed on the table does not apply and a new bursting reinforcement for the anchorage should be calculated.

Note: Changes may be made to the information contained in this brochure at any time as new techniques and/or materials are developed.

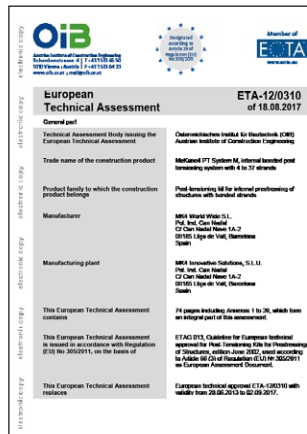

MK4

Innovative
Solutions

 **FORTEC**





MK4

Innovative
Solutions

www.mekano4.com

Calle Can Nadal s/n Nave 1-A
08185 Lliça de Vall
Barcelona – Spain

+34 938 63 42 50
mk4@mekano4.com

 **Mekano4**